



USER MANUAL



MAKARA-MK3

Double 21"
Powered Subwoofer

Table of Contents

3	Overview	11	Power Distribution
4	Quick Start Guide	11	Troubleshooting
5	Combining Speakers	12	Cardioid Mode
6	Outboard Processor Warning	14	Specifications
6	Setup Procedure	16	Warranty
7	Operation and Controls	17	Safety Information
8	Indicator LEDs	18	Important Notes
9	How to Use the Presets	18	FCC Compliance Notice
10	Pre-Installed Onboard Presets	18	Manufacturer

Este manual está disponible en español en nuestro sitio web en bassboss.com/support

Overview

You recognize that music continues to expand into the space below the limits of conventional subwoofers, down into the depths of frequencies, the depths of emotions. You don't want to be left behind, just on the surface, you want to plunge into these new depths and take your audiences with you on this exciting journey!

But you can't abandon those on shore, the music from before the technology allowed this downward expansion and the music that doesn't take advantage of or need to reach these depths, so you still need to be able to do everything you've always done. You need something that's not ONLY going to do the deepest lows, you need something that's going to excel at everything all your previous subs have needed to do and ADD a whole new dimension.

This dimension is the one that surrounds us, envelops us, connects us, unifies us and makes us feel that we are all having the same experience. When the frequencies go lower, the wavelengths get longer and the music, quite literally, gets bigger.

If you want your performances to be bigger, the way to do that is to make the music bigger with these bigger waves. More people and more emotions can fit within bigger music. With the Makara, you can make the performances, the emotions and the impact of your system bigger without making your system too big to manage and without leaving anyone behind, except, perhaps, your competition...

The Makara-MK3 features 5,000W of amplification, with an auto-sensing, globally compatible power supply that can run on input voltages anywhere between 90 and 250 Volts. Full output power is available on anything over 110V. The amplifier's peak-output voltage provides intense, high SPL hits while its sustained output is unparalleled in its ability to deliver the liquid lows. The amplifier is passively cooled via its external heat sink and by woofer-generated air flow through the port. When necessary, four radial fans will engage to provide additional forced-air cooling capacity in more extreme conditions.

Amplifier power is converted into the much more desirable acoustical power by two high-sensitivity, neodymium motor, 21-inch woofers with 4.5-inch (115mm) high-BL voice coils. Neodymium magnets are lighter, and their higher intensity provides higher efficiency, so the result is a lighter and louder cabinet than those with ferrite drivers. Our split-wound woofer coils create a more consistent force throughout the cone's range of movement, minimizing distortion and enhancing linearity at peak output.

The protection systems involve several techniques running simultaneously to effectively prevent thermal overload of the voice coils and limit excessive excursion. Reducing thermal saturation not only prevents burned voice coils, it also minimizes long-term thermal compression. Due to the sophistication of these multiple, independent yet simultaneous processes, the drivers can be protected while the actions of the limiters have virtually no noticeable effect on the transient response of the loudspeaker. Peak output can be achieved consistently, repeatedly and safely.

The Makara-MK3 is a hybrid 6th-order bandpass cabinet, utilizing a large vented volume and two short-horn sections to increase sensitivity in its upper operating range. The best way to describe the Makara experience is "Complete". The complete subwoofer experience includes effortless depth and plenty of "punch". The two drivers are loaded into a large acoustical volume that is tuned to a low frequency, and each is front-loaded onto a short horn. The vented enclosure section provides extended deep bass performance and the horn section provides increased upper-frequency sensitivity and improved transient response.

The enclosures feature UHMW Polyethylene sliders on the top and bottom, with corresponding recesses in the opposite sides to facilitate interlocking the boxes when stacked. The available transport carts also feature recesses for the sliders to facilitate secure transporting.

The MK3 features an all-new DSP. The comprehensive suite of processing includes high-pass and low-pass filters as well as multiple protection systems and limiters to prevent driver overload in as many ways as possible, including thermal, excursion and clipping. The five levels of protection actively prevent overheating of the voice coil, minimize long-term thermal compression and limit excursion. Because they operate in 5 different modes, the limiters are sophisticated enough to have a largely unnoticeable effect on the transient response and allow the subwoofer to deliver peak output safely.

The new DSP features an Ethernet interface. This can be used to control the cabinets from a computer or to load the ControlBASS software and settings updates. The Ethernet connectivity in conjunction with the DSP board allows signal to be sent via Milan AVB. Future updates will provide access to this feature.

Within the ControlBASS software, multiple cabinets can be grouped together, allowing them to respond to commands simultaneously. This permits the levels of multiple loudspeakers to be adjusted together and yet independently from the levels of other groups of loudspeakers. In addition to individual and grouped level controls, presets can be loaded and signal levels and temperatures can be monitored. Each cabinet includes a two-port switch so multiple cabinets can be chained on the same data cable.

The MK3 DSP features storage capacity of up to 100 presets, eight of which can be accessed at the touch of a button with no need for a connected computer. The eight directly accessible presets are compatible with all the presets in the MK3 Top Boxes and are also compatible with previous generation tops and subs.

Quick Start Guide

1 Ensure the cabinet is secure and stable, on level ground.

4 Connect the XLR-M connector to additional subs or tops.

2 Attach any poles/additional mid-high cabinets to the subwoofer.

5 Connect the mains power and verify the "Ready" LED is lit.

3 Connect the signal cable via the XLR-F input.

Combining Speakers

BASSBOSS systems are easy to set up quickly. The best possible results are achieved consistently because of the integrated nature of the designs. All BASSBOSS loudspeakers are complete, integrated systems, featuring the cabinet, transducer, amplifier and a comprehensive suite of processing. Setup is particularly easy because the products integrate with each other.

Provided the cabinets are physically aligned, any BASSBOSS sub can be combined with any BASSBOSS top and their outputs will be phase-coherent. This means no cancellations and no gaps in the response at the crossover frequency, regardless of which preset is selected.

The on-board BASSBOSS processing allows for the following: Any BASSBOSS powered subwoofer can be combined with any other BASSBOSS Powered subwoofer and their outputs will sum coherently. (i.e. in phase with each other.)

Any BASSBOSS powered subwoofer or combination of BASSBOSS powered subwoofers can be combined with any BASSBOSS powered top and their outputs will sum coherently through the crossover region.

HOWEVER only one model of top should be used at a time. An assortment of different tops cannot be stacked together and still achieve coherence and clarity. Putting tops of similar or different models not designed for side-array usage next to one another creates comb-filtering and significantly degrades sound quality.

The following tops should be used individually, i.e. should NOT be arrayed

AT312

(Co-axial point-source top)

DiaMon

(Co-axial point-source satellite)

SV9

(2-way monitor with Satellite mode)

The following tops can be used in arrays

MFLA

(Medium Format Line Array, up to 20 cabinets can be arrayed)

AT212

(Horizontally arrayable when necessary)

DV12

(Arrayable in PAIRS ONLY with the upper box of the pair inverted.)

Outboard Processing Warning

Third-party outboard processing (Drive Racks, etc.) are not recommended and are not necessary with BASSBOSS MK3 series powered loudspeakers. Outboard processing will not improve, and will very likely degrade the sound quality, reliability and output capacity. Using external processing inappropriately can cause driver damage that is not covered by warranty.

The internal processing can accomplish everything an external processor could accomplish without degrading the sound quality and without putting components at risk. Before considering using an outboard processor, contact BASSBOSS customer service with your use-case scenario for assistance in setting up the internal processing to achieve your goals.

Setup Procedure

Once the cabinet is in the desired location, signal cables should be connected via the XLR-F input. It's recommended to run balanced signal cables to minimize the chance of noise and ground-loop hum. **The incoming signal should be unprocessed because all the necessary processing is done in the built-in DSP.** The signal should be run directly from the outputs of a mixer or controller.

The XLR-M connector provides a full-range, unprocessed, pass-through connection to additional cabinets. This output can be connected to additional subs or tops. Up to 12 cabinets can be connected on a single output from a mixer or controller.

Connecting the mains power The power connector is a Neutrik PowerCON TOP waterproof type. The power connector inserts with the silver tab rotated counter clockwise from vertical, at about the 1000 position, and once inserted, rotates clockwise to the 1200 position to lock in place. Once locked, this connector is waterproof.

This connector also serves as the power switch. To disconnect and remove the connector, pull back on the silver tab to unlock it and rotate it counter clockwise. Once rotated to the insertion angle, the connector can be removed.

When connecting and disconnecting, no force should need to be applied. If the connector doesn't insert and rotate smoothly, either it's in the wrong position or it's damaged and should be replaced.

Always use a grounded outlet. The supplied power cord includes a standard grounding NEMA 5-15 (Edison) 120-Volt US wall plug. In unfamiliar locations it's recommended to verify the correct wiring of outlets before powering your system.

It's highly recommended to connect all signal and power cords to the speakers before plugging the power cords into mains outlets. When your speaker is powered on, you'll see all the indicator lights turn on and then show the system's current status.

Operation & Controls

There are 2 controls on the amplifier.

1 Input

This knob adjusts the input level from -72dB to -0dB. To avoid distortion and clipping, make sure the input signal doesn't exceed +22dB and the output doesn't reach clipping before you achieve the desired sound level.

While the amplifier has built-in limiters and safety features to protect itself and the speaker, it can't protect the speaker from distorted incoming signals. The amplifier will simply amplify the clipped signal, which can do the same damage as clipping an amplifier. Since it's essentially impossible for these amplifiers to clip, signal-level clipping is the most common cause of damage to the speaker.

2 Preset Select

Pressing the Preset Select button cycles through presets 1-8, and pressing it again after preset 8 returns to preset 1.

Each preset includes all necessary low-pass and high-pass filters at the selected frequencies and all the necessary alignments to maintain phase coherence in the crossover range when used with other BASSBOSS powered speakers.

Presets help you fine-tune the balance between the subwoofers and top speakers. More details on the different combinations are on page 9.

If you hear distortion, lower the input level right away. While rare, distortion can happen, and if the signal is clean this indicates the driver has reached its physical capabilities.

Indicator LEDs

Indicator LEDs - Left side, bottom to top

Ready	Power is on and the system is ready to play.
Signal	Input signal is present.
-12dB	12dB of headroom remaining before reaching maximum output.
-6dB	6dB of headroom remaining before reaching maximum output.
Limiting	A channel is reducing the incoming signal level to prevent overdrive.
Overheat	The amplifier is reducing output to prevent shut-down from overheating.
Protect	The amplifier is shut down due to a condition that could cause damage.

The Protect LED also is engaged when the system has been muted via the software.

Comm Link	Indicates communication is active on the LAN connection(s).
-----------	---

Indicator LEDs, Right Side, Bottom to top

Presets 1-8

The illuminated LED indicates the corresponding preset is loaded.

How to Use the Presets



Setting the low-pass filter frequency on the subwoofer to match the top cabinet's high-pass filter frequency and balancing their levels will achieve the smoothest sound across the frequency range.

There are no incompatible combinations.

Selecting high numbered presets on subs with low-numbered presets on tops will result in increased

system output in the overlap range, which can be helpful in some situations but can also result in a "boomy" sound.

When the subwoofer levels are to be run higher than tops levels, (which is almost always) the effective crossover moves higher in frequency. If you intend to run your system "bass-heavy" it's recommended to run lower-numbered presets on the subs and higher-numbered presets on the tops to avoid an excessively "boomy" sound.

Selecting low-numbered presets on subs with high-numbered presets on tops may result in a lack of "punch" in certain combinations. This is most likely when not enough level is available from the subwoofer(s).

When not enough output is available from the sub(s), using a preset combination with overlap can help provide a little more bass level but it does limit the maximum level of the tops due to the added demand for low-frequencies from the tops.

It's recommended that you try several, if not all, combinations when first setting up to determine which combination works best in each environment. You will likely choose different combinations for wood floors, concrete floors and outdoors.

Experiment with different combinations to dial in your preferred combination in different environments.

Pre-Installed Onboard Presets

High-pass and low-pass filters with included phase compensation.

Preset 1	23 Hz - 60 Hz
Preset 2	23 Hz - 70 Hz
Preset 3	23 Hz - 75 Hz
Preset 4	23 Hz - 80 Hz
Preset 5	23 Hz - 85 Hz
Preset 6	23 Hz - 90 Hz
Preset 7	23 Hz - 95 Hz
Preset 8	Cardioid Mode (Use only what cabinet is facing away from the audience.)

**Preset 8 is the Cardioid mode setting. More information on using Cardioid Mode can be found on page 12.

IMPORTANT - Update NOW!

ControlBASS + Settings

For improved performance and stability, update your settings immediately upon receipt of your new gear!

Major new updates are available.

Download new settings updates and the ControlBASS app at bassboss.com/software

Instructions on using the software, linking to your computer for remote monitoring and control and updating the settings files will be provided when you sign up!

Register your gear
bassboss.com/support

For more information and setup tips on how to get the best and most out of your system check out the Knowledge BASS help.bassboss.com

In order to achieve the flattest and smoothest frequency response, you should match the levels of your BASSBOSS subs and tops, and the low-pass filter frequency selected on the Subwoofer(s) should be closely matched to the high-pass filter frequency selected on the Top(s).

On the other hand, if you like your system to be bass-heavy, and you plan to turn your subs up louder than your tops, you may want to choose a preset on the tops with a high-pass frequency that's slightly above the frequency chosen on the subs. This will reduce the chance of an output peak in the crossover/overlap range and will allow slightly more output SPL from the tops.

Power Distribution

Connect no more than one 5000W or two 2500W subwoofer amplifiers to a single 20A circuit. If you need to share circuits don't exceed two BASSBOSS single-driver subwoofers or one double-driver subwoofer along with one or two top speakers on the same circuit.

Although amplifiers for tops and subs may be specified to have the same power capacity, amplifiers used for tops applications tend to draw significantly less current. Subwoofers draw far more current than tops due to the demands for level and the duration of the notes.

The amplifiers can operate on mains supply from 100 to 250VAC. To connect to voltages other than 120V, a different mains connector plug must be used. Contact your salesperson for information about purchasing cables for alternate voltages.

Pass-through Power connections can be used to power additional cabinets. With optional True 1 TOP cables, power can be linked between subs and tops. Do not connect equipment that will draw more than 15A on a single power outlet. Contact your salesperson for information about linking power cables.

Avoid powering all subwoofers on the same circuit. Instead, use separate circuits for each subwoofer and top speaker combo to help prevent overloading a single circuit and tripping a breaker.



Troubleshooting

If, after following the previous instructions for setup, you have no output from the loudspeaker

Verify that the green Ready LED is lit. If NOT lit, check the following

1. Is the power cord plugged into a live outlet?
2. Is the Neutrik powerCON connector rotated into the locked position?

If the green Ready LED is lit, check the following

1. Is the red Protect LED illuminated? The unit may be in protect mode or set into mute via software.
2. Is the signal cable connected to the input?
3. Is the signal cable connected to an operating output at the other end?
4. Is there signal flowing to the input? Check the integrity of the cable against a different cable.
5. Is the volume knob turned all the way down or at a very low level?
6. Is the signal flowing to the input full-range?

Filters in the signal may remove the operating frequencies of the loudspeaker receiving them.

7. If you're connected via LAN, check the level and filter settings in the software.

Cardioid Mode

Preset 8 Cardioid Mode

To achieve cardioid operation, you need at least one subwoofer facing the audience and one cabinet in cardioid mode placed facing away from the audience. Ideally, you should have two cabinets facing the audience and one facing away from the audience. The cabinets facing the audience should have the same preset loaded in them. The cabinet facing away from the audience should be set to the Cardioid preset - Preset 8. The Cardioid Mode cabinet should be placed between the audience-facing cabinets for cancellation directly behind the array.

The main subwoofer cabinets face the audience and use one of the first 7 presets, while the cardioid cabinet faces away from the audience with Preset 8 selected. When two cabinets are facing forward and one is facing backward in cardioid mode, set the input levels the same for all cabinets, with the same signal going to all. When one cabinet is facing forward and one is facing backward in cardioid mode, set the cardioid cabinet's level 6dB lower than the forward-facing cabinet, with both cabinets receiving the same signal.

If there's only one cabinet facing forward and another one facing backward in cardioid mode, you can place the cardioid cabinet on top of the forward-facing cabinet. If you place the cardioid cabinet next to the forward-facing cabinet, position the forward-facing cabinets further away from the stage or the area where you want to reduce sound levels. The most significant sound reduction happens along an imaginary line drawn from the center of the forward-facing cabinet's woofer back through the center of the cardioid cabinet's woofer.

How and When to Use Cardioid Mode

Cardioid mode doesn't make the sound louder for the audience. Instead, it reduces the bass level behind the subwoofer stacks. When you have two subwoofers facing the audience and add a third one in cardioid mode, the sound level in front of the two subwoofers won't change much. However, the sound level behind them will decrease.

In some situations a wall or structure may reflect the sound radiating from the rear of the subwoofers back towards the audience. That reflected sound can cause phase cancellations leading to a loss of impact and uneven frequency response. Cardioid mode can help eliminate those cancellations before they happen, leading to better sound quality and impact for the audience.

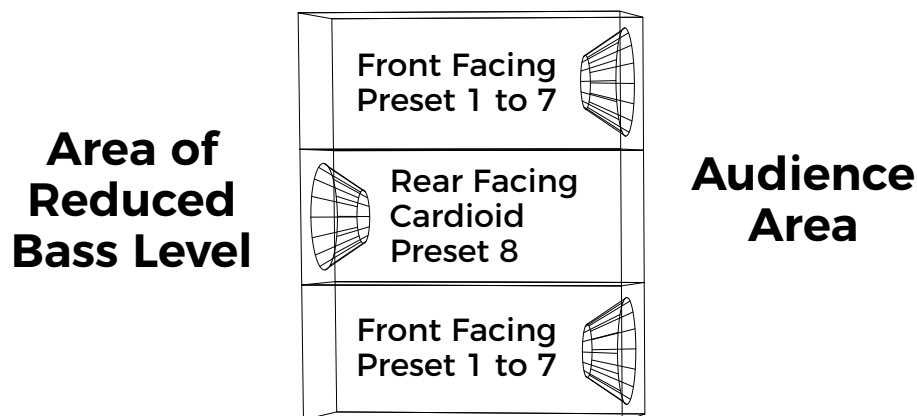

Specifications

Acoustical

Loudspeaker Description	New! Double 21" Self-Powered 6th-order Hybrid Subwoofer
Frequency Response (±3 dB)	23 – 100 Hz
Maximum Sustained Output	140 dB 1m (half-space)
Max SPL (Peak)	143 dB 1m (half-space)
Nominal Dispersion (H° x V°)	360 x 360 – Cardioid Mode Available with Multiple Boxes

Electrical

Amplification	5000 Watts Class D (2 x 2500W)
Processing	Integrated comprehensive DSP. 96kHz sampling rate with 8 pushbutton presets. All presets include high pass filters, low pass filters, phase alignment, equalization and multi-stage limiting. Storage capacity for up to 100 presets
Electrical Connectors, Amp	Neutrik powerCON True 1 TOP - IP65 rated waterproof connectors
Electrical Connector, Mains	USA 3-pin grounding 120V electrical plug NEMA 5-15; Outside USA alternate connectors provided
Voltage Operating Range	100-240V AC, 50-60Hz (Auto-sensing, auto switching universal supply)
Current Draw, Nominal	120V 9A (nominal); 240V 7A (nominal)
Signal Input Connectors	XLR-F
Signal Output Connectors	XLR-M pass-through only
LAN Connectors	EtherCON RJ45 (x2) with 2-port Ethernet switch

Physical

Enclosure Type	Vented, short-horn hybrid
Transducer	2 x 21 in. diameter (540mm) neodymium motor woofer with 4.5 in. (115mm) voice coil
Cabinet Construction	CNC machined 18mm Birch plywood with extensive bracing and dado joinery. 4 steel bar handles. 4 x 35mm steel pole sockets, 4 x interlocking UHMWPE sliders/feet.
Dimensions (HxWxD)	28 in. x 48 in. x 36 in. (28.5 in. high with feet)
Net Weight	294 lbs. (133 kg)
Shipping Weight	320 lbs. (145 kg) with pallet
Exterior Finish	High-pressure, bonded polyurea coating. Rugged, waterproof. Textured black
Grilles	Perforated, powder-coated steel
Feet	4 x UHMWPE sliders
Handles	4 x Steel bar handles
Fly Points	None. Ground-stack only
What's Included	Loudspeaker, 15' (5m) Power Cable, Manual, Warranty Card

Optional

Covers	Heavy-duty padded nylon transport covers for 1 cabinet
Dollies	Birch plywood flat cart with 4 locking wheels and recesses to accept the cabinet sliders. Transports 1 to 3 cabinets
Online Information	bassboss.com/makara

Our proactive philosophy causes specifications to be subject to change whenever improvements are made.

Warranty

WARRANTY INFORMATION | Our fully-transferable warranty covers all BASSBOSS products.

STANDARD CABINET WARRANTY

BASSBOSS loudspeaker cabinet integrity, including all joinery, fasteners, handles and wood, is warranted against defects in materials and workmanship for a period of six (6) years from the date of purchase. This warranty does not cover items that are intended to wear and can be replaced if worn or damaged. Examples of items not covered by this warranty are cabinet feet, grilles and the finish or coating applied to the cabinet.

ENHANCED COMPONENT WARRANTY

BASSBOSS amplifiers and electronic components are covered against failures due to defects in materials and/or workmanship for a period of three (3) years from the date of purchase.

TRANSDUCER WARRANTY

Transducers are covered against failures due to defects in materials and/or workmanship for two (2) years from the date of purchase.

WARRANTY SUPPORT

Warranty support is a service, and part of that service includes helping you prevent failures and minimize repair and shipping costs. Please contact BASSBOSS immediately if you observe an issue.

Please do not ship products without obtaining a return authorization number (RMA) by contacting BASSBOSS at bassboss.com/support. **If you need to ship your speaker for service, BASSBOSS technicians will provide assistance on shipping and packaging requirements specific to your service needs.**

WARRANTY LIMITATIONS

During the warranty period, if your loudspeaker malfunctions or fails due to any defect in components or manufacturing, the failed parts will be repaired or replaced. This warranty does not extend to damage resulting from improper installation, misuse, neglect or abuse. Warranty coverage and eligibility will be determined upon inspection by BASSBOSS personnel. This warranty does not cover labor other than that authorized and performed by BASSBOSS personnel. Service will be performed upon the return of the failed unit, together with its original sales receipt or other proof of purchase, to BASSBOSS or an Authorized Service Facility. Purchaser is responsible for all costs of shipping and handling. Cosmetic damage is specifically excluded from this warranty. This warranty is rendered void if service, repairs and/or modifications are attempted or made by anyone not specifically authorized by BASSBOSS to perform said services. ***Please contact BASSBOSS or your local BASSBOSS dealer before attempting any repairs and before shipping parts in for service.*** This warranty gives you specific legal rights, and you may also have other rights, which vary from state to state.

Safety Information

Important information regarding safety and the use of your loudspeakers

To prevent potentially dangerous exposure to high levels of acoustic pressure never stand in the immediate vicinity of loudspeakers driven at a high level without hearing protection. Professional loudspeaker systems are capable of causing sound pressure levels detrimental to human health. When a transducer capable of producing high sound levels is being used it is necessary to wear ear plugs or protective earphones to prevent hearing damage.

Even seemingly non-critical sound levels (from approximately 95 dB SPL) can cause hearing damage if people are exposed to it over a long period. Anyone exposed to these levels should use appropriate hearing protection devices. System and venue owners and operators are encouraged to make hearing protection devices available to all customers and staff members.

Warning:

In order to prevent accidents when setting up the loudspeakers or loudspeaker stands, make sure they are standing on a firm surface. Ensure that all hardware, fixings and fasteners used for installation or mobile deployment are of an appropriate size and load safety factor. Use only the factory installed, internally secured M10 fly points when suspending cabinets above the ground. Use only appropriately load-rated hardware. When suspending cabinets from their fly-points, use at least 4 (four) of the fly points on the cabinet and always attach to multiple points of the supporting structure. Pay attention to these instructions and follow the relevant safety guidelines in your area. Always use hardware that is approved for overhead lifting.

Check the security/tightness of all load-bearing fasteners regularly. Check all hardware for visible signs of wear and tear. Replace them when necessary. Not all models include these fly points. If your cabinet does not include these fly-points, it is not intended to be flown. Never hang loudspeakers from handles. Never drill or screw into cabinets to attach lifting points.

Only use included, factory installed, internally secured M10 fly points when supporting cabinets. (Not all models include these fly points.) Only use appropriately load-rated hardware. Never hang loudspeakers from handles. Never drill or screw into cabinets to attach lifting points.

Pay attention to the manufacturers' instructions and to the relevant safety guidelines. Regularly check the loudspeaker housings and accessories for visible signs of wear and tear, and replace them when necessary. Regularly check all load bearing bolts in the mounting devices.

Caution Loudspeakers produce a static magnetic field even if they are not connected or are not in use. Therefore make sure when erecting and transporting loudspeakers that they are nowhere near equipment and objects which may be impaired or damaged by an external magnetic field. A distance of 3 feet (1m) should be maintained between loudspeakers and sensitive equipment such as CRT monitors or magnetic storage media.

Never attempt to carry out any operations, modifications or repairs that are not expressly described in this manual. Contact your dealer or BASSBOSS support if the product is not functioning properly.

The audio system must comply with current local standards and regulations regarding electrical systems. For installation purposes, BASSBOSS strongly recommends that this product be installed by a qualified, professional installer who can ensure correct installation and certify that it is installed in compliance with the regulations in force.

The audio system must comply with current local standards and regulations regarding electrical systems.

Important Notes

Shielded data cables must be used.

To minimize the occurrence of noise and interference, always use shielded signal cables. Avoid routing signal or data cables close to equipment that produces high-intensity electromagnetic fields such as transformers, power cables and loudspeaker wires.

Do not coil excess power cable. Do not coil or wrap power cables and signal or data cables together.



WARNING

This is a class A product. In a domestic environment, this product may cause radio interferences, in which case the user may be required to take corrective measures.

FCC Compliance Notice

Note This equipment has been tested and found to comply with the limits for a Class A digital device, pursuant to part 15 of the FCC Rules. These limits are designed to provide reasonable protection against harmful interference when the equipment is operated in a commercial environment.

This equipment generates, uses and can radiate radio frequency energy and, if not installed and used in accordance with the instruction manual, may cause harmful interference to radio communications. Operation of this equipment in a residential area is likely to cause harmful interference in which case the user will be required to correct the interference at their own expense.

Manufacturer

True Lee Loudspeakers | BASSBOSS 2028 E Ben White Blvd. #240-8220 Austin TX 78741

We declare, under our sole responsibility, that to the best of our knowledge to which this declaration relates, our products are in conformity with the applicable requirements.

Product	Makara-MK3 Subwoofer
Intended use	Professional Audio Loudspeaker

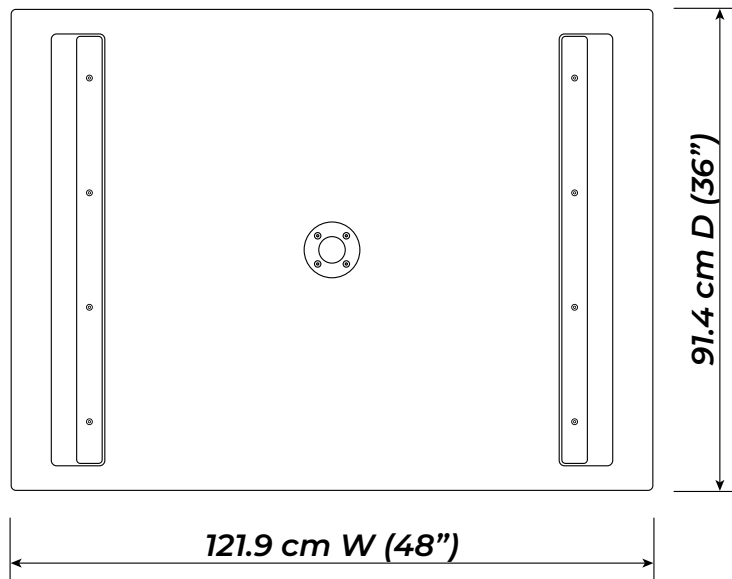
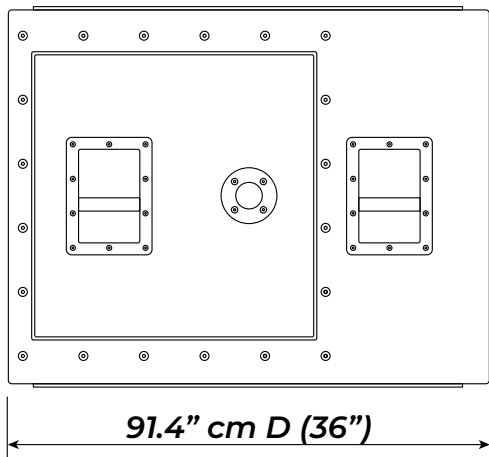
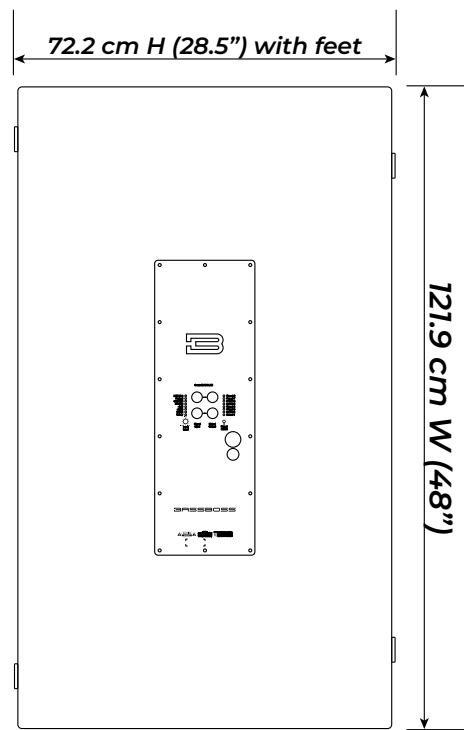
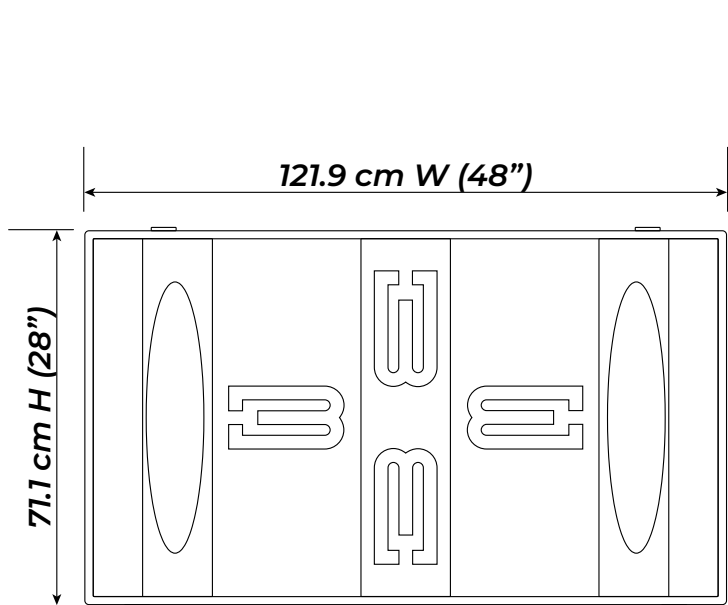

MAKARA-MK3

Double 21"
Powered Subwoofer



Need more assistance?
We're here to help.

help.bassboss.com